



cIAPMO-T®

LPG GAS ON DEMAND
WATER HEATER

11 Sunnybrook Drive
Cincinnati, OH. 45237
Phone: 513-641-4446 * 800-934-9690
Fax: 513-641-0733
www.precisiontemp.com

Certified to ANSI Z21.10.3 / CSA4.3

Model
RV-550-EC

This water heater design has been certified to ANSI Z21.10.3 / CSA 4.3 standards by the IAPMO. **This water heater is not for use in space heating applications.**

SERVICE CALLS & QUESTIONS

Locations and phone numbers of qualified Service Centers can be found at our website www.precisiontemp.com or call 800-934-9690 Ext. 109 to obtain service information.

Installation, Operation and Maintenance
Effective 1/18

CRITICAL INSTALLATION WARNINGS

- All combustion air must be supplied from outside the RV, and all products of combustion must be vented to outside the RV.
- DO NOT vent water heater with venting system serving another appliance.
- DO NOT vent water heater to an outside enclosed porch area.
- Protect building materials from flue gasses.
- DO NOT modify water heater in any way.
- DO NOT alter water heater for a positive grounding system.
- DO NOT HI-POT water heater unless electronic ignition system (circuit board) has been disconnected.
- DO NOT use battery charger to supply power to water heater even when testing.

WARNING: If the information in these instructions is not followed exactly, a fire or explosion may result causing property damage, personal injury or loss of life.

— Do not store or use gasoline or other flammable vapors and liquids in the vicinity of this or any other appliance.

WHAT TO DO IF YOU SMELL GAS

- Evacuate all persons from the vehicle.
- Shut off the gas supply at the gas container or source.
- Do not touch any electrical switch, or use any phone or radio in the vehicle.
- Do not start the vehicle's engine or electric generator.
- Contact the nearest gas supplier or qualified service technician for repairs.
- If you cannot reach a gas supplier or qualified service technician, contact the nearest fire department
- Do not turn on the gas supply until the gas leak(s) has been repaired.

Installation and service must be performed by a qualified installer, service agency, OEM or the gas supplier.

USA and Canada – Follow all applicable state and local codes. In the absence of local codes or regulations, refer to the current standards of:

- Local codes or, in the absence of local codes, the *National Fuel Gas Code, ANSI Z223.1/NFPA 54* and/or *CSA B149.1, Natural Gas and Propane Installation Code.*
- Local codes or, in the absence of local codes, the *Standard on Recreational Vehicles, NFPA1192* and/or *CAN/CSA-Z240 RV.*

CLEARANCE Requirements

Sides, top and bottom - 0"

Back - Enough to make connections, but no less than 2.5"

Front - Enough to remote access cover for service, but no less than 10". Unit should be installed where it can draw combustion air into the bottom directly from the coach exterior and flued through the 2" flue pipe to the exterior. The combustion air source and flue pipe must be totally isolated from the inside of the coach.

**CAUTION
PRODUCT DAMAGE**

All connections must be made using TWO (2) wrenches to avoid twisting and damaging lines. Damage voids the Warranty!

GENERAL INSTALLATION

The following instruction describes the most common type of installation for the water heater. However, there are other approved methods such as baggage compartment and flush mounting. Consult your Field Auditor, Account Manager, or the PrecisionTemp Service Department if you have additional questions.

These steps assume the proper location has been determined and is being installed at the OEM prior to erecting the walls. NOTE: Parts bag that includes corner filler brackets and optional water fittings.

1. Locate the water heater on the floor of the coach at pre-determined location. The unit must be permanently supported at the same level as the bottom of the sidewall cutout (by the floor or a raised floor).
2. To install the unit on carpeting, assure the addition of metal or wood under the unit is added and extends a minimum of three inches beyond the width and depth of the appliance enclosure. Minimum clearance requirement is zero (except front door for proper operation and service).
3. If risk of future connection leakage and damage of adjacent area is of concern, install a drain pan under the unit with drainage to outside of vehicle.
4. Connect plumbing to water lines taking care to make correct "COLD" and "HOT" orientation. Connect 3/8" FM flared LP gas line to 3/8" M flared gas fitting.
 - a. Allow flexibility in water and gas lines so the unit can be pulled through the sidewall opening at least one inch past the skin, allowing for sealing step.
 - b. Assure the water and gas line grommets continue to be intact and properly inserted in the case holes, with no gaps or openings where the line passes through the case.

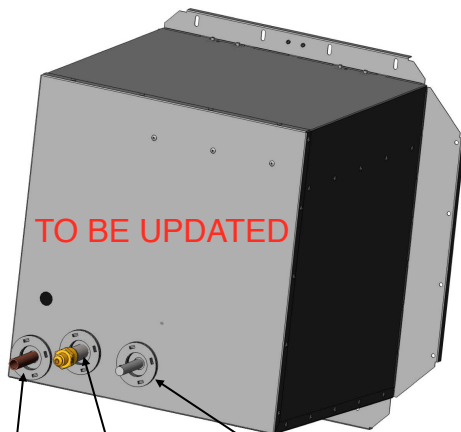

Cold In Gas Connection Hot Out 2

5. Cut the opening or orient the pre-fabricated opening. Frame with 2" x 2" lumber (or equivalent).

6. Pull the unit outward through the opening and bend all four flanges outward 90 degrees along the lanced lines.

Installation in water heater opening

7. To **prevent water leaks**, caulk thoroughly around the backside of the flanges over the lanced bend slots. Caulk the perimeter of the opening (or substitute 1" x 3/8" Butyl Tape).
8. Push the unit to the wall against the caulking and secure the corner brackets behind the unit flanges but snug to the corner of the enclosure. Complete the installation by inserting #8 screws in all the flange holes. An "air tight" seal must be the final result.
9. Place the access door on the lower flange pins aligning the holes in the bottom of the door. Carefully close the top edge of the door, being careful to align the flue opening with the flue tube and screw in the fastener.
10. The appliance must be disconnected from the gas supply piping system during any pressure testing of the system at test pressures in excess of 1/2 psi. The appliance must be isolated from the gas piping system during any pressure testing at test pressures equal to or less than 1/2 psi. Pressure inlet to valve, 13" W.C. maximum, 11" W.C. minimum. Pressure at outlet of valve is factory set at 10: Burner manifold pressure is W.C. 8.9" W.C. +/- .2" at tap on burner manifold.

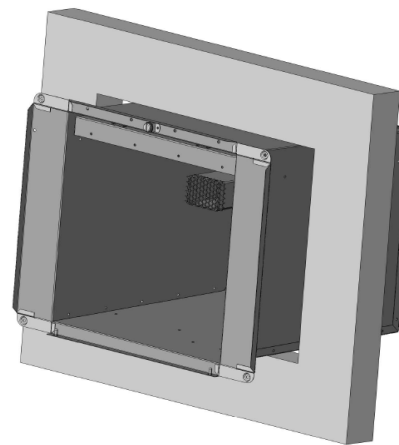

**WARNING
FIRE AND/OR EXPLOSION**

• DO NOT use matches, candles or other sources of ignition when checking for gas leaks.

11. Turn on the gas and check the water heater and all connections for gas leaks with a leak detecting solution.
12. Turn on water supply line and check for water leaks.

WIRING INSTRUCTIONS

The appliance must be disconnected from the gas supply piping system during any pressure testing of the system at test pressures in excess of ½ psi. The appliance must be isolated from the gas piping system during any pressure testing at test pressures equal to or less than ½ psi. Pressure inlet to valve, 13" W.C. maximum, 11" W.C. minimum. Pressure at outlet of valve is factory set at 10". Burner manifold pressure is W.C. 8.9" W.C. +/- .2" at tap on burner manifold.

PRESSURE RELIEF VALVE

THIS VALVE IS A SAFETY COMPONENT AND MUST NOT BE REMOVED FOR ANY REASON OTHER THAN REPLACEMENT.

This water heater is equipped with a pressure relief valve that complies with the standard for Relief Valves and Automatic Gas Shutoff Devices for Hot Water Systems, ANSI Z21.22 / CSA 4.4.

This valve protects against excessive water expansion only. This water heater has separate and dedicated protection for excessive heat.

If you use a discharge line, do not use a reducing coupling or other restriction smaller than the outlet of the relief valve.

Allow complete drainage of both valve and line.

FOR REPLACEMENT PARTS:

- DO NOT install anything less than a pressure relief valve certified by a nationally recognized testing laboratory that maintains periodic inspection of product of listed equipment or materials, as meeting requirements for Relief Valves and Automatic Gas Shutoff Devices of Hot Water Supply Systems, ANSI Z21.22 / CSA 4.4. Valve must have maximum set pressure **not to exceed 100 psi**.
- Install replacement valve into opening provided and designated for this purpose on water heater.
- Installation must conform with local codes or in the absence of local codes, Standard on Recreational Vehicles, ANSI A119.2 or CAN/CSA-Z240RV.

Heater must be connected to fully rectified 12 VDC current, taking care to assure **RED lead is connected to +12 VDC (positive)** supply and **green wire connected to -12VDC (negative)** connections. Reversing polarity or connecting to AC power will damage the equipment which is not covered by warranty.

The appliance, when installed, must be electrically grounded in accordance with local codes or, in the absence of local codes, with the *National Electrical Code, ANSI/NFPA 70* and/or the *CSA C22.1, Canadian Electrical Code*.

CAUTION ELECTRICAL DAMAGE
Label all wires prior to disconnection when servicing controls. Wiring errors can cause improper and dangerous operation. Verify proper operation after servicing.

 WARNING FIRE AND/OR EXPLOSION
<ul style="list-style-type: none"> • DO NOT use matches, candles or other sources of ignition when checking for gas leaks.

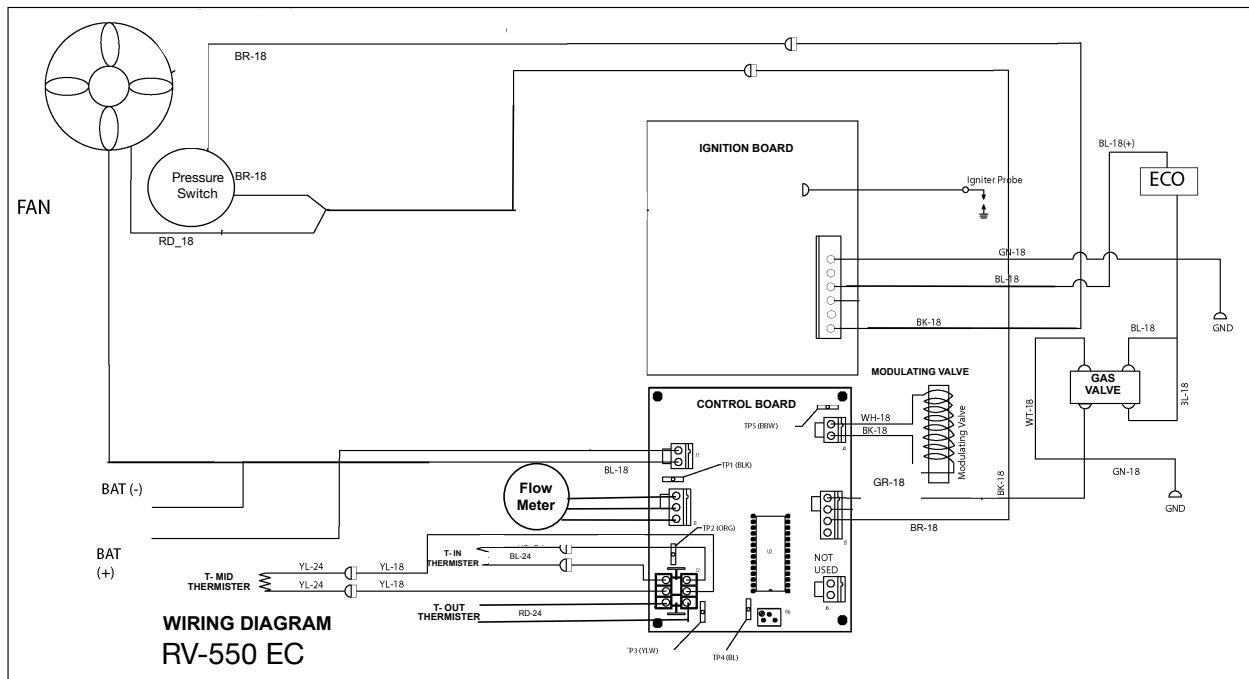

HOW TO OPERATE YOUR WATER HEATER



- Do not smoke or have any flame near an open faucet.

If water heater has not been used for more than two weeks, hydrogen gas may form in water line. Under these conditions to reduce the risk of injury, open hot water faucet for several minutes at kitchen sink before you use any electrical appliance connected to hot water system.

If hydrogen gas is present, you will probably hear sounds like air escaping through the pipe as water begins to flow.

- 1) Pressurize the water system by turning on pump or city water pressure.
- 2) Purge all air from the system by turning on the faucets until a steady stream of water flows.
- 3) Turn on the 12V DC power supply.
- 4) Turn on the LP supply at the tank and the manual gas valve (if installed). The water heater will remain dormant until a water tap is opened and the heater senses water flow of at least 0.5 GPM.
- 5) Turn on the hot water tap to full open. The heater will fire up within several seconds and hot water will flow from the tap in the time it takes to traverse the lines from the heater to the faucet. (If this is the first usage, you may have to turn the water on and off several times to purge the LP gas lines of air. If the heater fails to light or the lockout lamp (optional) illuminates, turn the power switch OFF, then ON to reset the ignition control. After ignition water flow can be reduced cold water added as desired.
- 6) To shut off the water heater, shut off the water. Shut off power at remote switch or breaker.
- 7) Should overheating occur or the gas supply fail to shut off, turn off the "ON/OFF" power switch.

A Note About "Navy Showers" When Dry Camping

It is recommended to take a shower just like you would at home. That is, leave the water running through the entire shower. The hot water system is designed to deliver a continuous, comfortable flow of hot water and that's the way it works best.

Shutting off the shower with the showerhead button wastes water. Each time this is done, the showerhead "trickles", filling the hot water line with cold water. This cold water has to be purged from the line each time the showerhead is turned back on. Tests have shown that this will not save water and sometimes uses more water than leaving the shower run continuously.

GENERAL INFORMATION

- LP and Water system must be turned on.
- Have gas pressure tested periodically. Should be set at 11 inches of water column with three appliances running.
- Drain water heater at regular intervals (at least one time during the year).
- Drain water heater before storing RV for the winter or when the possibility of freezing exists.
- Keep vent and combustion air grill clear of any obstructions.

ELECTRONIC IGNITION MAINTENANCE

- The water heater comes factory-equipped with a fused circuit board, which will protect the circuit board from wiring shorts. If the fuse should activate, the water heater will not operate. Before replacing the fuse, check for a short external to the board. Once the short is corrected, replace the 2 amp fuse with a mini ATO style fuse. Do not install a fuse larger than 3 amps.
- If the fuse is good and the unit is inoperative, check for excessively high voltage to the unit (more than 14 volts).

Winter Operation and Winterizing Water

This heater is equipped with freeze protection that will prevent freezing under most conditions. In order for it to function, 12 VOLT AND GAS SUPPLY MUST REMAIN TURNED ON. This allows the burner to fire and electric elements to protect the system. Any freezing of the water heater or other plumbing components can cause severe damage that is not covered by warranty.

Winter Traveling Operation:

In some areas all LPG appliances must remain off when coach is in motion. If this is the case, drain heater as follows:

1. Turn off water pump and the power and gas to the heater. Open the pressure relief valve by lifting the handle to a 90° position from the normal position.
2. Open at least one hot and cold water tap in the coach. This should drain the system.

Winterizing Procedure:

Before storing the system for the winter, the plumbing system must be winterized. This can be done by either of the following methods:

1. All water should be drained from the system. To do this, open one tap at a time using compressed air to purge the system of all water.
2. Recommendations of your coach manufacturer should be followed. The water system can be filled with RV, non-toxic anti-freeze. When you see the anti-freeze coming from the hot water tap, the heater is protected.

RV-550- EC and NSP-550-EC Component Layout

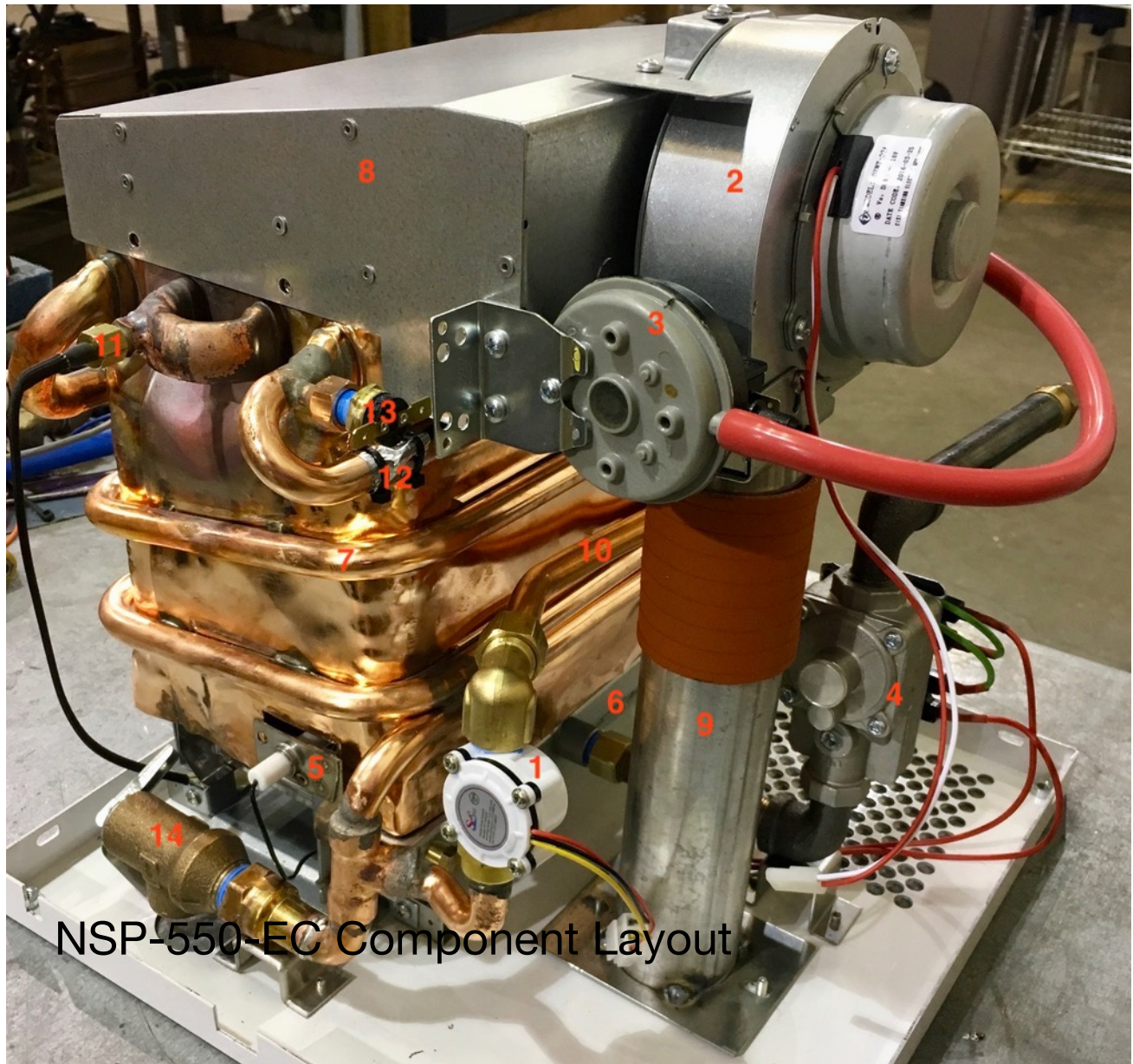

NSP-550-EC Component Layout

- | | | | |
|-----|-------------------------------|-----|-----------------------------|
| 1. | Hall Sensor Flow Meter | 15. | Gas Modulation Valve |
| 2. | Power Vent | | NOT PICTURED |
| 3. | Fluing Vacuum Switch | 16. | 12 VDC Relay |
| 4. | Combination Gas Valve | 17. | Control Board |
| 5. | Igniter / Proofing Probe | 18. | Direct Spark Ignition Board |
| 6. | Manifold and Burner | | |
| 7. | Finned Tube Heat Exchanger | | |
| 8. | Flue Hood | | |
| 9. | Flue Pipe | | |
| 10. | T-In Thermistor | | |
| 11. | T-Mid Thermistor | | |
| 12. | T-Out Thermistor | | |
| 13. | 165°F ECO | | |
| 14. | 100 PSI Pressure Relief Valve | | |

NOTE
COMPONENT LAYOUT OF
RV-550-EC IS IDENTICAL TO
NSP-550-EC EXCEPT FOR FLUING
ORIENTATION WHICH FLUES
THROUGH TOP/FRONT RATHER
THAN BOTTOM.

TROUBLESHOOTING

Most problems are easily remedied by consulting the trouble-shooting guide. If problems still persist, contact PrecisionTemp or an authorized service center. Only a qualified technician should do any work involving the gas system.

A periodic visual check of the burner flames should be done by observing the flame through the "peep hole" in the heat exchanger. There should be blue flame with minimum or no yellow tipping. There should be nothing obstructing the flow of combustion and ventilation air.

Burner maintenance should be performed by a PrecisionTemp Authorized Service Technician.

NOTE: The heater is dormant until it senses water flow. When a water tap is turned on to at least .4 GPM the burner will fire until water flow is turned off and the heater again goes dormant.

Heater Does Not Come On When The Water is turned on. (Power vent not running)

1. Be sure power is on and panel breaker is not tripped.
2. Check electrical contacts. Be sure the connector is plugged into board. Using a voltmeter, check for 12Volts on this connector.
3. Be sure all electrical connectors are secure and the polarity is correct. (Red wire to positive terminal).
4. Fuse in power wire might be blown. Replace fuse.
5. Locate the ECO, high temperature switch (red and purple wires) at the upper left hand of the heat exchanger. Check for open circuit condition. The ECO should be reset by pushing the reset button when temperature drops below 160 degrees.
6. Be sure there is a battery in the system. Never connect the heater directly to a power converter. Some converters have circuits that are not pure DC. This can cause malfunctions or damage to the heater and is not covered by warranty.
7. Be sure that no water-mixing valve has been left in the on position, using the showerhead as a shut off. This will permit water to bypass the water heater and bleed cold water into the hot water system. Always turn off both hot and cold water valves after using.
8. Be sure that the bypass valve at the water plumbing connections is in the "off" position. An open valve can also permit water to bypass heater, causing it not to fire.

There Is No Ignition When Water Is On (Power vent is running)

1. Be sure the gas valve at the tank is "On", there is gas in the tank and the gas line is purged of all air.
2. Be sure that water flow is at least 0.5 gallon/minute.
3. Check that the ignition wire is plugged into the spark tower on the ignition control and is not touching anything else.
4. Check flame site hole to see if igniter is sparking from the probe to the burner. Contact *PrecisionTemp* or your nearest authorized service representative.
5. Check that there are no cuts or breaks in the wire. Align it so that it is not in contact with anything but the terminal.
6. Be sure that the power vent fan has 12 volts to it when there is water flowing and there are no obstructions in the flue pipe.
7. Safety pressure switch may be out of adjustment. Contact PrecisionTemp or your nearest authorized service representative.

No Water Flows From Tap When Tap is Turned on.

1. Be sure that water supply is turned on and that there are no obstructions.
2. Hot and cold water lines connected to heater are reversed. Correct by reversing their positions.

Burner Turns On But Temperature Fluctuates Erratically.

1. May be caused by excessive restriction at the water outlets, showerheads, aerators or water strainers. These should be cleaned and any showerhead flow restrictor removed.
2. If temperature fluctuates as the pump cycles, a pressure accumulator tank is needed in the water system. If you have an accumulator tank, check to see if it has become filled with water. If it has, drain it so that it contains air only.

Heater Comes On But Rapidly Cycles On And Off.

1. Water flow is too low. Increase flow at a tap. Clean all aerators and shower head screens to assure at least .4 GPM of water flow
2. Water pump is not functioning properly. Repair or replace pump.
3. If the heater cycles as the pump cycles, a pressure accumulator tank is needed in the water system. If you have an accumulator tank, check to see if it has become filled with water. If it has, drain it so that it contains air only.
4. Air is in the water line. Bleed air by turning on all water taps.

Burner Ignites But Water Temperature Is too low

1. The water flow may be so high as to exceed the capacity of the heater particularly if your supply water is very cold. Slow the water flow.
2. The gas pressure may be too low. Be sure the gas flow control valve is in full "on" position.
3. Check the gas pressure while the water is on at full flow. The LPG pressure should be the "manifold pressure" as shown on the specification label while the heater is running. A gas-testing gauge should be installed on the manifold tap so that it may be read while heater is running. If it is too low, turn up the gas regulator to the proper pressure. This should only be done by a qualified technician.
4. The gas flow may be too low due to improper gas line diameter (under 3/8 inch outside diameter). The gas line may be excessively long (over 20-30 feet) or the on/off solenoid at the tank (if you have one) may have an orifice that is too small (under 3/16th of an inch).
5. Check the heater door louvers and flue pipe for airflow obstructions and clean.
6. Check that the "summer / winter" valve is in the proper position for the temperature of the incoming water.

Water Temperature Is Too Hot or No Temperature Control.

1. Fuel tank regulator is set too high and manifold pressure as described above Have the regulator checked by a qualified technician.
2. Water flow too low for incoming water temperature.

Low Heat Rise and Excessive Water Flow Is Required To Trigger Water Heater

If you find that your heater requires excessive flow to activate it (much over .5 gallon per minute), it is likely that you have cold water bleeding into the hot water side of your water system.

1. Check that valves and faucets are closed when not in use. If there is an on/off button on your showerhead, always turn the water valves off after the shower to prevent cold water from bleeding into the hot water system. This will keep the heater from functioning properly.
2. Be sure that the bypass valve at the water plumbing connections is in the "off" position. An open valve can also permit water to bypass heater, causing it not to fire.

If any problem persists, contact an authorized service center or *PrecisionTemp*.

***PrecisionTemp, Inc.* WATER HEATER LIMITED WARRANTY**

PrecisionTemp, Inc warrants to the original owner and subject to the below mentioned conditions, that this product will be free of defects in material or workmanship for a period of two years from the original date of purchase. PrecisionTemp's liability hereunder is limited to the replacement of the product, repair of the product, or replacement of the product with a reconditioned product at the discretion of the manufacturer. This warranty is void if the product

has been damaged by accident, unreasonable use, neglect, tampering or other causes not arising from defects in material workmanship.

This warranty extends to the original owner of the product only and is subject to the following conditions:

1. For a period of two years from the date of purchase, PrecisionTemp will replace the complete water heater if the heat exchanger leaks due to corrosion. This warranty includes reasonable labor charges required to replace the complete water heater.
 2. For two years from the date of purchase, PrecisionTemp will repair or replace any part defective in material or workmanship. This warranty includes reasonable labor charges, required to remove and replace the part. Service calls to customer's location are not considered part of these charges and are, therefore, the responsibility of the owner.
 3. This warranty does not cover the following items classified as normal maintenance:
 - a. adjustment of gas pressure
 - b. cleaning or replacement of burner orifices
 - c. cleaning or adjustment of burner assembly
 - d. cleaning or adjustment of flue
 - e. adjustment of pressure relief valve
 4. **In the event of a warranty claim, the owner must contact, in advance, either an authorized PrecisionTemp Service Center or the PrecisionTemp Service Department. Warranty claim service must be performed at an authorized PrecisionTemp Service Center (a list will be provided at no charge) or as approved, PrecisionTemp, Inc**
11 Sunnybrook Dr. Cincinnati, OH 45237, 800-934-9690 Ext. 109. Return parts (or water heater) must be shipped to PrecisionTemp "Prepaid". The defective parts (or water heater) become the property of PrecisionTemp and must be returned to the Service Department,
PrecisionTemp, Inc. 11 Sunnybrook Dr. Cincinnati, OH 45237.
 6. This warranty applies only if the unit is installed according to the installation instructions provided and complies with local and state codes.
 7. The warranty period on replacement parts (or water heater) is the unused portion of the original warranty period or ninety (90) days, whichever is greater.
 8. Damage or failure resulting from misuse (including failure to seek proper repair service), misapplication, alterations, water damage, or freezing are the owner's responsibility.
 9. PrecisionTemp does not assume responsibility for any loss of use of vehicle, loss of time, inconvenience, expense for gasoline, telephone, travel, lodging, loss or damage to personal property or revenues. Some states do not allow the exclusion or limitation of incidental or consequential damages, so the above limitations or exclusions may not apply to you.
 10. Any implied warranties are limited to two (2) years. Some states do not allow limitations on how long an implied warranty lasts, so the above limitation may not apply to you. This warranty gives you specific legal rights and you may also have other rights which vary from state to state.
 11. Replacement parts (components or tanks) purchased outside of the original water heater warranty carry a 90 day warranty. This includes the part at no charge.
- This PrecisionTemp heater is designed for use in recreational vehicles, park models, mobile food carts and marine applications for the purpose of heating water as stated in the "data plate" attached to the water heater. Any other use, unless authorized in writing by the PrecisionTemp Engineering Department, voids this warranty.

11 Sunnybrook Drive
Cincinnati, OH. 45237
Phone: 513-641-4446 * 800-934-9690
Fax: 513-641-0733
www.precisiontemp.com

